

Design and Analysis of High Efficient Pifa-L Bend Antenna for Mobile Handsets

L.FRANKLIN TELFER
Assistant Professor, RIT
Chennai, TN 602107, India
franklintelfer21@gmail.com

K.KALAIARASAN
Research Scholar, REC
Chennai, TN 602105, India
calebkamal@gmail.com

Abstract — This prototype is based on designing and analysis of size optimized planar inverted-F antenna (PIFA) with L bend element, accommodated on a printed circuit board (PCB) for mobile handsets and operating at 2.68GHz. This antenna have a principle advantage of reduce size, low cost manufacturing, high bandwidth utility. Different parametric analysis has been performed with the handset dimension of about 88x44 mm. The antenna design and simulations are done using HFSS.

Key Words — FR4 substrate, HFSS, PIFA-L

I. INTRODUCTION

PIFA can be considered as a kind of linear Inverted F antenna (IFA) with the wire radiator element replaced by a plate to expand the bandwidth [1]. The Planar Inverted-F antenna (PIFA) is increasingly used in the mobile phone market. The antenna is nearly resonant at the quarter wavelength thus reducing the required space needed on the phone, and also typically has good SAR properties [3].

The general structure of PIFA antenna is given in Fig 1.

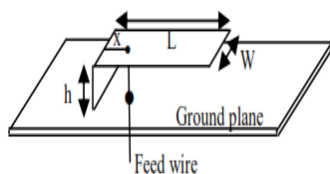

Fig.1. The Planar Inverted-F Antenna (PIFA).

The PIFA is designed to operate at 2.68 GHz by the equation in (1):

$$fr = c [4 (W + L)]^{-1} \quad (1)$$

Where c is the velocity of light. Fr , W and L are, respectively be the width, length and centre frequency as given in Table 1.

1.1 General PIFA dimension

One method of reducing PIFA size is simply by shortening the antenna. However, this approach affects the impedance at the antenna terminals such that the radiation resistance becomes reactive as well. This can be compensated with capacitive top loading. In practice, the missing antenna height is replaced with an equivalent circuit, which improves the impedance match and the efficiency [2]. The capacitive loading reduces the resonance length from $\lambda/4$ to less than $\lambda/8$ at the expense of bandwidth and good matching [5]. The capacitive load can be produced by adding a plate (parallel to the ground)

to produce a parallel plate capacitor as shown in Fig 2.

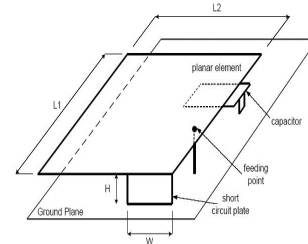

Fig.2. General PIFA Dimension

II. MATERIAL CONSIDERATIONS

The metallic patch is normally made of thin copper foil. The substrate material provides mechanical support for the radiating patch elements. It also maintains the required spacing between the patch and its ground plane. The substrate thickness for the basic geometry is in the range of 0.01 to 0.05 free-space wavelength. The dielectric constant ranges from 1 to 10 and can be separated into three categories.

1. Those having a relative dielectric constant (relative permittivity) in the range of 1.0 to 2.0. This type of material can be air, polystyrene foam, or dielectric honeycomb.

2. Those having a relative dielectric constant in the range of 2.0 to 4.0. This type of material consists mostly of Fiber-glass reinforced Teflon.

3. Those with a relative dielectric constant between 4.0 and 10.0. This type of material can be ceramic, quartz, or alumina.

The most commonly used material is Teflon-based with a relative permittivity between 2 and 3. This material is also called PTFE (Poly Tera Fluoro Ethylene). It has a structure very similar to fiberglass material used for digital circuit boards, but has a much lower loss tangent. Cost, power loss, and performance are trade-off considerations in choosing the substrate material, as illustrated by the following examples [6]. For example, a single patch or an array of a few elements may be fabricated on a low-cost fiberglass material at the L-band frequency, while a 20-element array at 30 GHz may have to use higher-cost, but lower loss, Teflon-based material (loss tangent less than 0.005). For a large number of array elements at lower microwave frequencies (below 15 GHz), a dielectric honeycomb or foam panel may be used as a substrate to minimize loss, antenna mass, and material cost while having increased bandwidth performance. There are materials with relative dielectric constant higher than 10. The patch size is smaller for higher dielectric constant.

However, higher dielectric constant also reduces bandwidth and radiation efficiency [4].

III. PROPOSED ANTENNA STRUCTURE AND DESIGN DATA

The PIFA-L antenna structure is based on the PIFA antenna design, its design data is given in Table 1 and its dimensions are shown in fig 3.

PIFA-L design data		
Sl no*	Parameters	mm
1	Solution frequency(GHz)	2.68
2	Antenna length 1	21.86
3	Antenna length 2	7.02
4	Antenna length 3	47.26
5	Antenna trace width	1.32
6	Antenna offset	3.95
7	Feed offset	-4.39
8	Feed length	0.132
9	Feed width	1.32
10	Substrate thickness	62mil
11	Substrate dimension along x	44
12	Substrate dimension along y	88

Table 1. PIFA- L Design Data

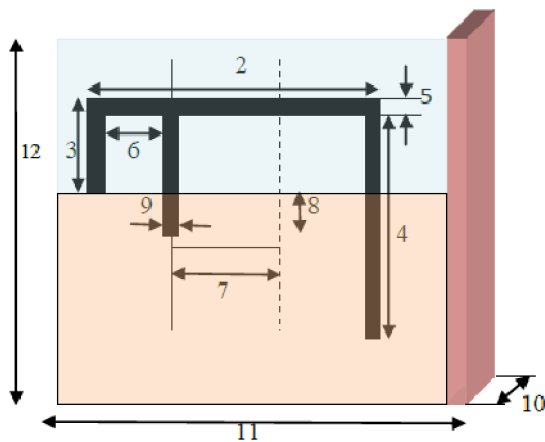

Fig.3. PIFA L antenna parameter dimensions (* - serial numbers from table 1 is used for identification in fig. 3)

3.1 Design Model Using HFSS

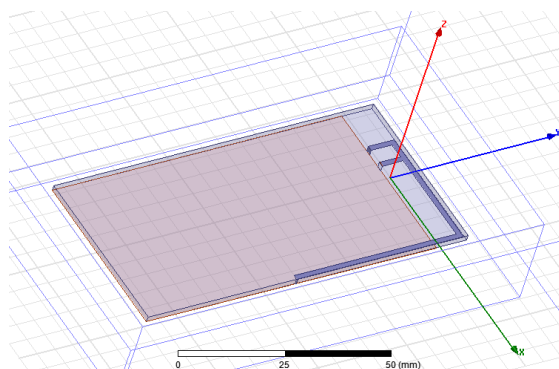

Fig.4. PIFA-L Antenna Model Using Ansoft HFSS.

In Fig 4, the XY plane model with a radiating box along XZ direction is provided, which makes the radiation defined at a specific co-ordinates microstrip feed is provided in antenna length 2 (as given in parametric design data) with a operating frequency of 2.68GHz.

Since coaxial feeding technique is used there is a loss in coupling between the SMA connector and female coaxial connector at antenna end. For further analysis fabrication is made by using FR4 substrate with alumina as radiating element formed as PIFA L shape, soldered via ground then coaxial soldering is done at antenna length 2 it is then tested with real time network analyzer for proper return loss, S11, directivity for comparison between simulated and measured results, but is estimated that the measured results vary from simulated due to manufacturing defects and flaws in substrate material.

IV. SIMULATED RESULTS

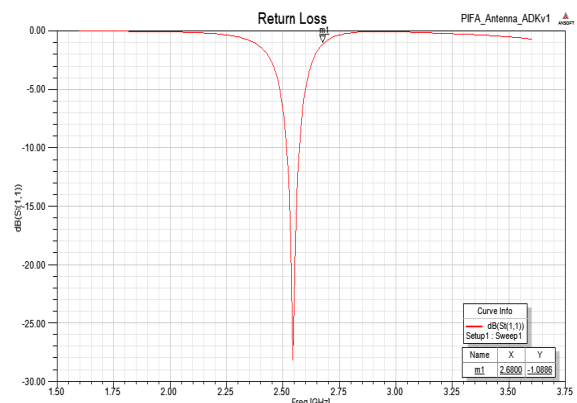

Fig.5.ReturnLoss

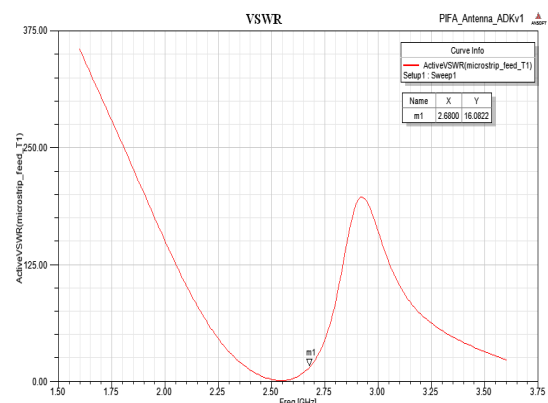

Fig.6. VSWR

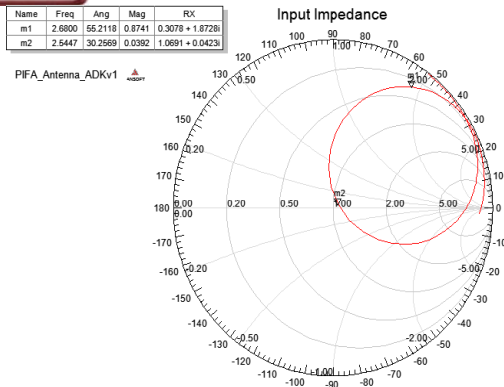

Fig.7. Input Impedance

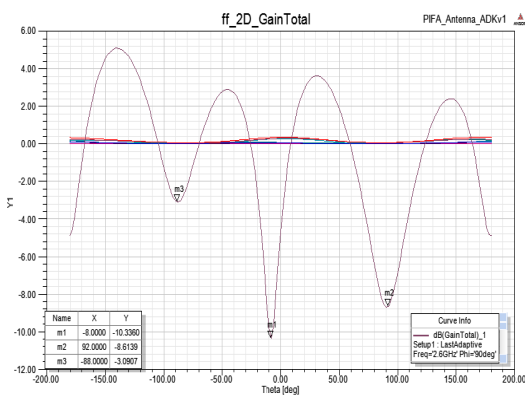

Fig.8. 2D Total gain plot

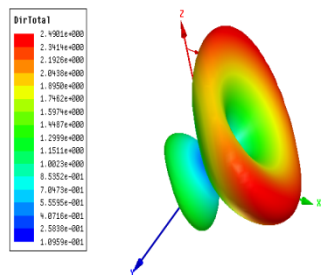

Fig.9. Directivity toward xyz plane

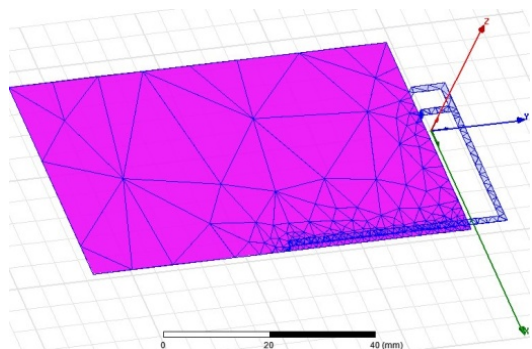

Fig.10. Mesh analysis

In Fig.3 the PIFA L- Bend structure is designed using Ansoft HFSS software simulator, the design specifications

are given in Table 1. The design is performed with a virtual radiation of outer box which covers the antenna and substrate, the substrate FR4 is applied within $\epsilon_r < 1$. In the Fig 5 it has good return loss at it tends to near centre frequency. In Fig 6 VSWR has more slanted towards the frequency, it has 2.68 GHz at m1 position. In Fig 8 2D total gain is plotted which at m1 highest gain vale plotted. In Fig 7 the input impedance is plotted using smith chart it gives high impedance at m2 region. In Fig 9 the directivity and total radiation pattern is plotted in 3D axis as maximum radiation propagates in X axis. In fig 10 the mesh analysis is done which gives complete mesh grouping for local SAR analysis.

V. COMPARATIVE RESULTS

The comparisons from three different antenna performances are given in Table 2.

Parameter	IFA	PIFA	PIFA-L
Centre Frequency	2.68Ghz	2.68Ghz	2.68Ghz
Mins11 Value	-17.94db	-20.2db	-28.0db
Vswr	1.290	2.500	2.6800
Radiation Pattern	Broader	Narrow	Broader

Table 2. Comparative Results

VI. CONCLUSION

The antenna design and analysis performance was simulated in Ansoft HFSS software. Further optimization and analysis can be performed with 4X4 antenna positioning at different location on the substrate which leads to more data rates tends to 4G technology with MIMO. Single meander and double meander structure can be designed along PIFA to get high data rate in mobile handset operating at 698 MHz to 960 MHz [4]. These PIFA antennas are mainly used in Multimedia application for 4G Mobile Phones. The proposed antenna has good radiation patterns and gain at different frequencies. Multiband design can be done by adding additional radiating branches [6].

REFERENCES

- [1] Hottinen, A., O. Tirkkonen, and R. Wichman, (2003) Multi-antenna Transceiver Techniques for 3G and Beyond, Wiley, West Sussex, England.
- [2] Foschini, G. J. and M. J. Gans, (1998) "On limits of wireless communications in a fading environment when using multiple antennas," Wireless Personal Commun., Vol. 6, 311-335.
- [3] 3GPP TS 36.101, V8.3.0, (2008) "EUTRA User Equipment Radio Transmission and Reception,".
- [4] L. Zheng, X. Zhang and S. Lai, (2006) "Resonant Characteristics of the Meander-line Dipole Antenna," Journal of Microwaves, vol. 3.

- [5] M. Ali, S. S. Stuchly, and K. Caputa, (1996) "A wide-band dual meandersleeveantenna," *J. Electromagn. Waves Application.*, vol. 10, no. 9, pp. 1223- 1236.
- [6] M. Ali, G. J. Hayes, H.-S. Hwang, and R. A. Sadler,(2003) "Design of a multiband internal antenna for Third generation mobile phone handsets," *IEEE Trans. Antennas Propagation.*, vol. 51, pp. 1452-1461.

AUTHOR'S PROFILE



Franklin Telfer. L.

Born in Chennai on 21st April 1988. He received B.E. degree in Electronics and Communication Engg, from S.A Engineering College, Affiliated to Anna University, Poonamalle, Chennai, in 2009, and M.E. Communication Systems, in S.A

Engineering College, 2012. His field of interest includes RF microwave, Antenna Design, Mobile Communication. He has presented six Papers in National conferences, four papers in International conferences and reviewer in two international conferences, Malaysia.



Kalaiarasan. K.

Born in Chennai on 31st July 1986. He received B.E. degree in Electronics and Communication Engg, from S.A Engineering College, Affiliated to Anna University, Poonamalle, Chennai, in 2009, and pursuing M. E. Communication Systems, in Rajalakshmi Engg. Coll. His field of interest includes Wireless communication, RF

microwave and Mobile communication.